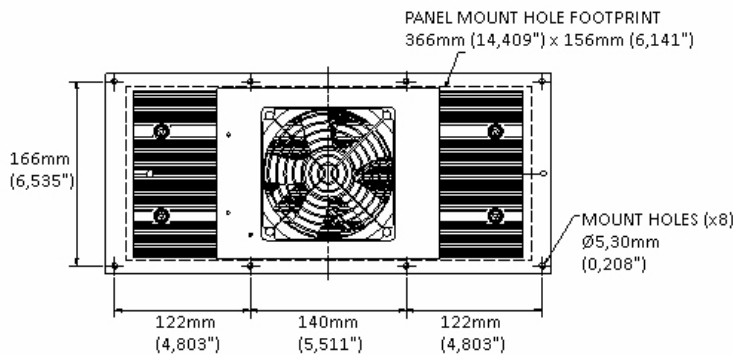

Image for illustration purposes only

Mounting Drawing



ΩDBK A200 Thermoelectric Cooler

ΩDBK SERIES AIR-TO-AIR THERMOELECTRIC COOLERS

The ΩDBK A200 is a 200W air to air thermoelectric cooler, employing forced air convection provided by IP54 axial fans.

It forms part of the ΩDBK standard range which provides assemblies from 60W to 200W.

Custom designs are available by request and DBK will be pleased to service your bespoke requirements including Direct and Liquid cooling.

FEATURES

- I. Compact Design
- II. DC Operation
- III. Reliable solid-state construction
- IV. RoHS compliant

Electronic Control Systems are available to complement the ΩDBK range.

Specifications

Rated Cooling Power (W)	200
Typical Current (A) (measured after 5mins @20°C)	12
Nominal Voltage (Vdc)	24 (options available)
Operating Temperature (°C / °F)	-10 to 50 / 14 to 122
Cold Side Airflow @zero static pressure (cfm)	107
Hot Side Airflow @zero static pressure (cfm)	135
L10 @40°C (fans - hrs)	65,000
Weight (approx. - kg)	7.5
Standard Lead Length (mm)	600 (23,622") (options available)
Length (mm) - L1 / L2	400 / 350 (15,748" / 13,779")
Width (mm) - W1 / W2 / W3	153 / 153 / 180 (6,023" / 6,023" / 7,086")
Height (mm) - H1 / H2	86 / 100 (3,385" / 3,937")

Outline Drawing

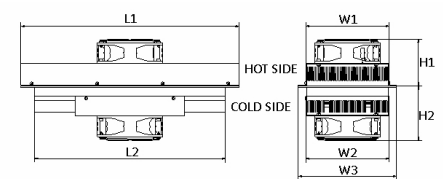

Typical Applications

- I. Electronics/Electrical Enclosures
- II. Analytical/Medical Instrumentation
- III. Industrial instrumentation
- IV. Food and beverage cooling
- V. Telecoms Cabinets

This information is subject to change without notice. Data is given for illustration purposes only and does not release the customer from independent application tests.

Measured Performance Data

ΩDBK A200 Thermoelectric Cooler

ΩDBK A200 Cooler Power vs ΔT

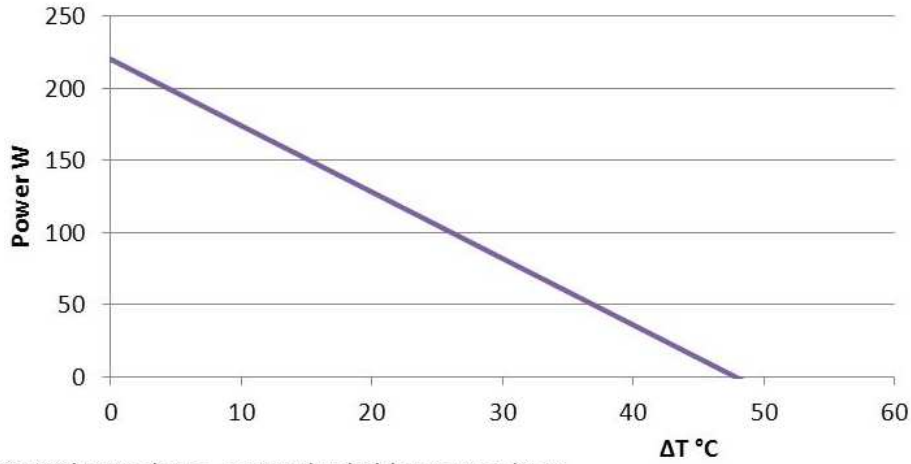

ΩDBK: Subject to change - measured under laboratory conditions

Wiring Information

In normal operation to provide cooling, the unit should be wired up as below. If required the unit can be operated with reverse polarity across the Cooler only to provide a heat source. The polarity supplied to the fans should not be changed.

Wire Colour	Function
Red	Cooler (16awg) and Fans (24awg) 24V +ve supply
Black	Cooler (16awg) and Fans (24awg) 24V -ve supply
Orange	HOT Side Safety Thermostat for overheat control
Blue	COLD Side Safety Thermostat for overheat control - only required when unit is operated in reverse polarity for use as a heater.

Typical Circuit Diagram

A typical circuit diagram is shown below to indicate use of a control thermostat such as ΩDBK FGT100 or FGT200 to maintain the enclosure temperature within the required conditions.

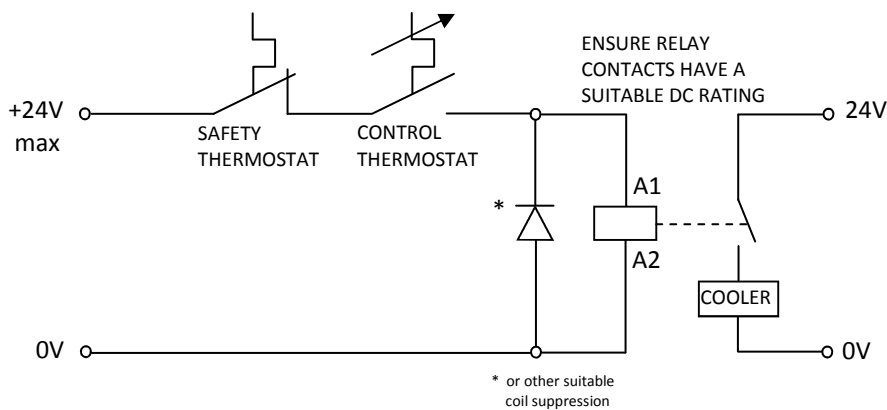

This information is subject to change without notice. Data is given for illustration purposes only and does not release the customer from independent application tests.