

Nimbus E



Nimbus E		90	120	150	200
Rated power at 10° C	[W]	80	100	120	150
External profile temp. (approx.)	[°C]	120	130	130	130
Voltage range		110 - 240 V, AC/DC			
Protection class		II			
System of protection		IP 20			
Connection cable 2 x 0,5 mm ² , silicone		500 mm long			
Fixing		DIN Clip for 35 mm rail EN50 022			
Approvals		VDE, UL, CSA			
Dimensions	LxWxH [mm]	90x82x35	120x82x35	150x82x35	200x82x35
Weight	[kg]	0.3	0.4	0.49	0.65
Recommended fuse (time-delay)	240 V	6,3A	6,3A	6,3A	6,3A
	110 V	4A	4A	4A	6,3A

Ordering Example: Nimbus E 90, 80 W, 110-240 V
 Special design 12 - 24V.

Special Features

- Optimum convection
- High power density

- 1 Fixing clip for 35 mm DIN top hat rail EN50 022
- 2 Aluminium profile
- 3 Cover plate
- 4 Strain relief
- 5 Silicone cable 2 x 0,5 mm² (AWG 20)

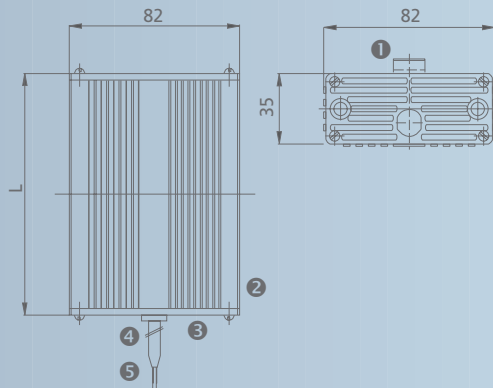

DBK David+Baader GmbH

Components

Rheinstrasse 72 - 74
 D - 76870 Kandel

Phone: + 49 (0) 72 75 7 03 - 231
 Fax: + 49 (0) 72 75 7 03 - 249

info@dbk-group.de
 www.dbk-components.com