

Nimbus B



Nimbus B		90		120		150		200	
Rated power at 10° C	[W]	30	50	40	60	50	75	80	100
External profile temp. (approx.)	[°C]	70	90	80	90	80	100	80	100
Voltage range		110 - 240 V, AC/DC							
Protection class		II							
System of protection		IP 20							
Connection cable 2 x 0,5 mm ² , silicone		500 mm long							
Fixing		DIN Clip for 35 mm rail EN50 022							
Approvals		VDE, UL, CSA							
Dimensions	LxWxH [mm]	90x82x35		120x82x35		150x82x35		200x82x35	
Weight	[kg]	0,29		0,38		0,48		0,64	
Recommended fuse (time-delay)	240 V	4A	6,3A	4A	6,3A	4A	6,3A	6,3A	6,3A
	110 V	2A	4A	2A	4A	2A	4A	4A	6,3A

Ordering Example: Nimbus B 120, 40 W, 110-240 V

Special design 12 - 24 V.

Special Features

- Thermal separation of the PTC heater from the external profile (patented)
- Limited external profile temperature
- Optimal convection

- 1 Fixing clip for 35 mm DIN top hat rail EN50 022
- 2 Aluminium profile
- 3 Cover plate
- 4 Strain relief
- 5 Silicone cable 2 x 0,5 mm² (AWG 20)

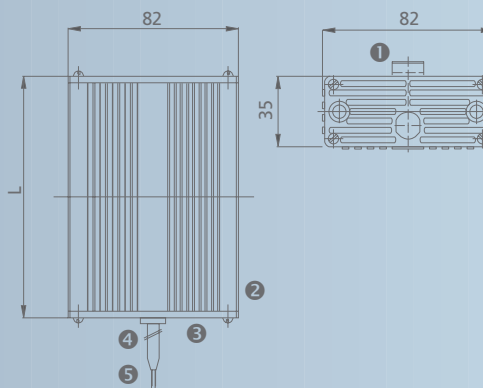

DBK David+Baader GmbH

Components

Rheinstrasse 72-74
D - 76870 Kandel

Phone: +49 (0) 72 75 7 03 - 231
Fax: +49 (0) 72 75 7 03 - 249

info@dbk-group.de
www.dbk-components.com